

# HR-Series

A perimeter illuminated sealed rocker switch, featuring a stylish, low profile actuator.

**PRODUCT WEBPAGE**

*request sample, configure part, watch video*



The HR-Series comes with a variety of dependent and independent illumination options; momentary and maintained circuits; and up to two customizable laser-etched legends. The patented design supports the various illumination options and allows the switch to be rated up to 20 amps, eliminating the need for relays.

**1-2** Poles    **12** VDC    **20** Amps    **IP68 Sealing** for above-panel components

## Typical Applications

- Marine
- On/Off-Highway
- Lawn Equipment
- Golf Carts
- Outdoor Construction Signage
- Any Application Requiring Sealing Protection

# Design Features

## 20A 12VDC RATING

Robust construction to handle a multitude of electrical loads.

## SNAP-IN MOUNTING

Fits into an industry standard mounting hole of 1.450 x .830 in. (Same as V-Series and W-Series)

## PERIMETER ILLUMINATION

Choice of independent (full) or dependent (half) lighting, in a variety of colors.

## IP68 ABOVE PANEL SEALING

Seals out dust and moisture.



## .110 TERMINALS

With dedicated TE connector for ease of installation. Sold Separately. (See General Specs for TE Part Numbers)

## MAINTAINED/ MOMENTARY

Circuits available in 2 or 3 positions.

## LASER ETCHED LEGENDS

Rocker icons convey a clean, sleek OEM look, with independent or dependent illumination.

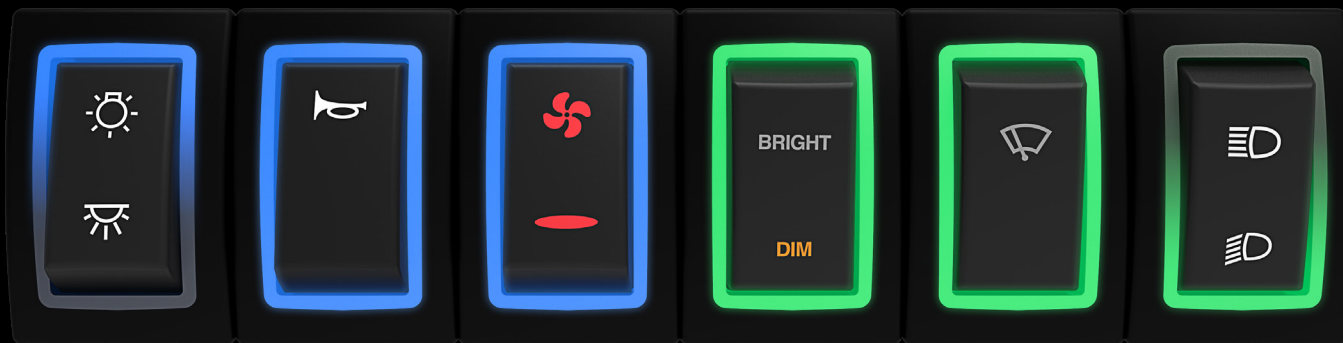

# Tech Specs

## Electrical

Operating Voltage	Designed for 12 Volt systems 9-16 VDC operating
Contact Rating	Maximum 20 amps at 12 VDC
Supply Voltage Ratings	The switch passes the following supply voltage testing: SAE J1455 section 4.13.1 for power-up, operating voltage, over voltage, reverse polarity, and short circuit
Dielectric Strength	Across open contacts: 500 V RMS AC for 1 minute From pole to pole (on multi-pole variants) 500 V RMS AC for 1 min.
Insulation Resistance	50 Megaohms
Initial Contact Resistance	10 milliohms max
Life	Up to 100,000 cycles, circuit and load dependent
Contacts	Silver tin-oxide
Terminals	Up to 10 external connector terminals 0.110" wide silver-plated copper terminals

## Mechanical

Endurance	200,000 cycles minimum, circuit dependent
-----------	---

## Physical

Illumination	One or two LED backlit laser marked icons (configurable to be independent or dependent). Uniform full or half perimeter illumination (configurable to be independent or dependent). Dimmable illumination (icons and perimeter), controlled by supply voltage. LEDs rated for 50,000 hour life
Seals	Internal
Base	Nylon, V-0 UL flammability rating
Actuator	Polycarbonate, V-2 UL flammability rating, painted and laser marked
Perimeter Lens	Polycarbonate, V-2 UL flammability rating
Bracket / Bezel	Polycarbonate polyester blend, V-0 UL flammability rating

## Actuator Travel (Angular Displacement)

2 Positions	24°
3 Positions	12° from center

## Environmental

Sealing	IP68, for above-panel components of actual switch only.
Operating Temperature	-40°C to 85°C The following codes were passed: Cold Soak (IEC 60068-2-1) Heat Soak (IEC 60068-2-2) Cycling/Shock (IEC 60068-2-14)
Vibration	General: IEC 60068-2-6, Swept sine wave section 8.2, 5 - 500 Hz 20 cycles 10g acceleration Resonance: IEC 60068-2-6, Vibration sinusoidal, section 8.1, 10 - 2000 Hz, 5g acceleration Random: IEC 60068-2-64, Method 1, random excitation, 10 - 350 Hz, 5 hours in each axis
Shock and Bump	IEC 60068-2-27, Shock 500 m/s <sup>2</sup> 11 milliseconds, Bump 200 m/s <sup>2</sup> 6 milliseconds 600 cycles
Salt Spray (Corrosion resistance)	IEC 60068-2-52, Test Kb, Severity level 4 (test duration 336 hours)
Moisture Resistance	MIL-STD-202 Method 103B, Test Condition A (240 hours)
Solar Radiation	IEC 60068-2-5, procedure B, 10 cycles, Total irradiation per cycle = 22.4 kWh/m <sup>2</sup>
Chemical Resistance	ISO 16750-5, spray or brush method. Gasoline, diesel fuel, motor oil, brake fluid, Armour all, Windex
Weathering/Cracking Resistance	ASTM D1171-99, method A, 72 hours
Abrasion / Wear Resistance	40 cycles of ASTM F2357 testing with 0.25" paper at 175 grams of force

## Connector

Switch mates with TE connector housing part number 1418994-1. Based on application wire size choose receptacle part number below (or equivalent):

1-968880-1	20-24 AWG wire
1-968849-1	17-20 AWG wire
1-968851-1	13.5-17 AWG wire
1-968853-1	12 AWG wire

## Mounting Specifications

Panel Thickness Range	0.062" to 0.187"
Panel Cutout	0.830" x 1.450" See Dimensions (same as V-Series and W-Series)

# Ordering Scheme

Sample Part Number **HR 11 D 1 A1 1 B A 1 - 1 1 - 00 00 0**

Selection 1 2 3 4 5 6 7 8 9 10 11 12 13 14

## 1. SERIES

**HR** Halo Illuminated Rocker Switch

## 2. CIRCUIT

( ) = momentary. SP = Single Pole. DP = Double Pole.

Position:		1	2	3
SP	DP	5&7, 6&8	Connected Terminals	3&5, 4&6
<b>11</b>	<b>21</b>	ON	NONE	OFF
<b>12</b>	<b>22</b>	(ON)	NONE	OFF
<b>14</b>	<b>24</b>	ON	NONE	ON
<b>15</b>	<b>25</b>	ON	NONE	(ON)
<b>16</b>	<b>26</b>	ON	OFF	ON
<b>18</b>	<b>28</b>	(ON)	OFF	(ON)

## 3. RATING (4)

**D** 20A 12V

## 4. TERMINAL / BASE STYLE

**1** .110 TAB (QC)

## 5. ILLUMINATION CIRCUIT (1, 2, 3)

Terminal Connections as viewed from back of switch:

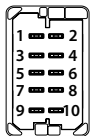

### FULL PERIMETER ILLUMINATION

Perimeter Illumination: Independent 9(+)-1(-) for codes A1 to A7

Rocker Illumination:  
2 and 3 Position Switches

**A1** Independent LED 1: 10(+)-1(-) LED 2: 2(+)-1(-)  
**A2** Independent LED 1: 10(+)-1(-) No Illumination  
**A3** No Illumination

2 Position Switch Position 1 Position 3  
**A4** Dependent LED 1: 5(+)-1(-) LED 2: 5(+)-1(-)  
**A5** Dependent LED 1: 10(+)-1(-) LED 2: 5(+)-1(-)  
**A6** Dependent LED 1: 5(+)-1(-) No Illumination

3 Position Switch Position 1 Position 2 Position 3  
**A7** Dependent LED 1: 5(+)-1(-) No Illumination LED 2: 5(+)-1(-)

### HALF PERIMETER ILLUMINATION

Rocker Illumination: LED 1 and 2: 10(+)-1(-)

Perimeter Illumination:

3 Position Switch Position 1 Position 2 Position 3  
**B1** Dependent Top Half On Full Illumination Bottom Half On  
 10(+)-2(+)-1(-) 10(+)-1(-) 10(+)-9(+)-1(-)

For a visual representation of the illumination options, see next page.  
 For custom illumination options, please consult factory.

## 6. PERIMETER STYLE

**1** Full Ring

## 7. PERIMETER ILLUMINATION COLOR

**B** Blue  
**G** Green

## 8. ROCKER ILLUMINATION COLOR

**Z** None  
**W** White  
**B** Blue  
**G** Green  
**A** Amber  
**R** Red

## 9. BRACKET COLOR

**1** Painted Black  
**2** Painted Silver

## 10. ROCKER COLOR

**1** Painted Black  
**2** Painted Silver

## 11. ROCKER STYLE

**1** Laser Etched

## 12. LEGEND

**00** No legend  
 For standard legends, see "Standard Legend Codes" page.  
 For additional legends, please consult factory

## 13. LEGEND

**00** No legend  
 For standard legends, see "Standard Legend Codes" page.  
 For additional legends, please consult factory

## 14. LEGEND ORIENTATION

**0** No legend  
**1** Orientation 1  
**2** Orientation 2  
**3** Orientation 3  
**4** Orientation 4

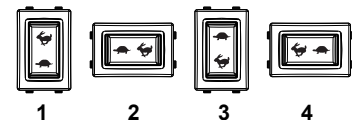

Notes:

- Code (A4) only available with 2 Position Circuits (14, 15, 24, 25)
- Codes (A5, A6) only available with 2 Position Circuits (11, 12, 13, 14, 15, 21, 22, 23, 24, 25)
- Codes (A7, B1) only available with 3 Position Circuits (16, 17, 18, 26, 27, 28)
- 1 milliamp is the recommended minimum load for the switch

# Illumination Options (Perimeter and Legend)

## Independent Illumination:

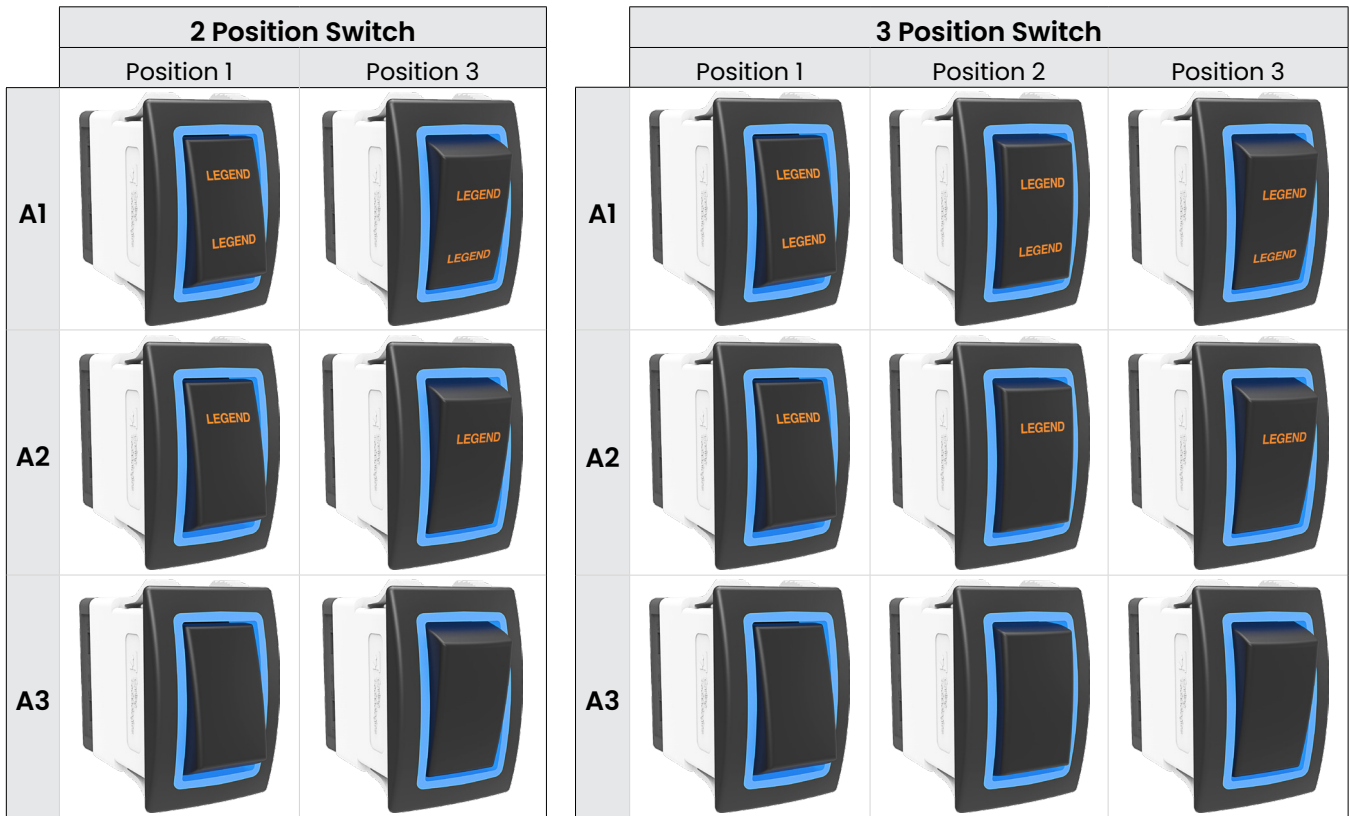

## Dependent Illumination:

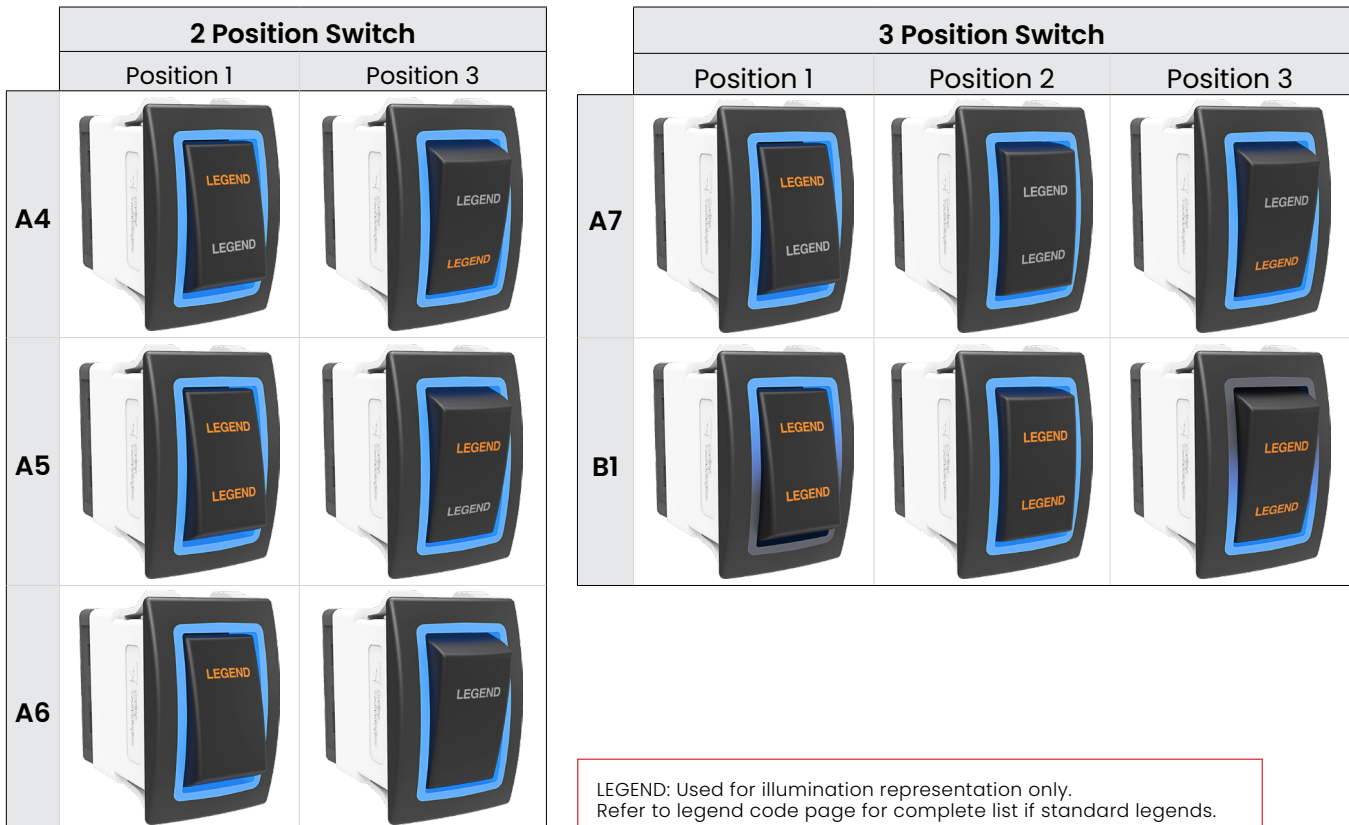

LEGEND: Used for illumination representation only.  
Refer to legend code page for complete list of standard legends.

# Dimensional Specs

inches [millimeters]

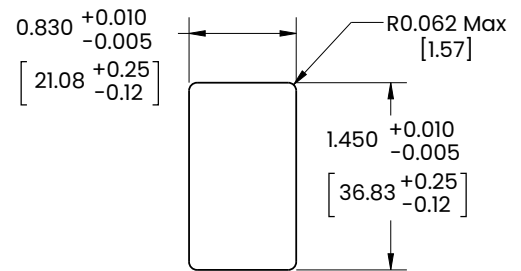
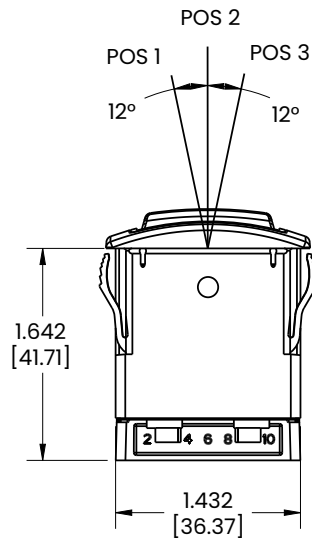
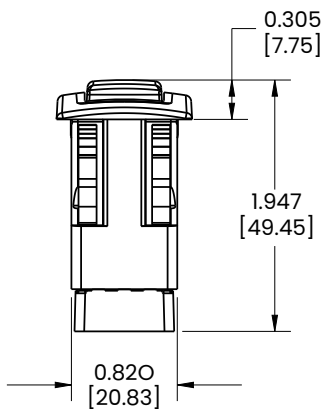
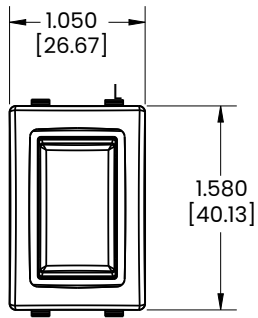

PANEL CUTOUT

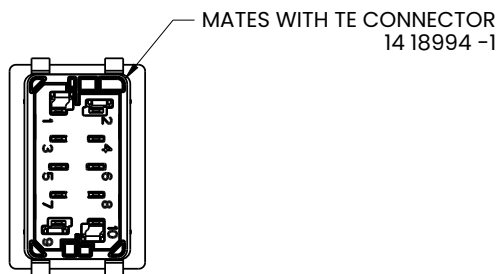

# Circuit Diagrams

Circuit Code	CIRCUIT DIAGRAM
11	
12	
14	
15	
16	
18	

Circuit Code	CIRCUIT DIAGRAM
21	
22	
24	
25	
26	
28	

Notes:  
1. Recommended minimum load per circuit is 1 milliamp

# Illumination Circuit Diagrams

illumination Code	ILLUMINATION CIRCUIT DIAGRAM
A1	
A2	
A3	
A4	

illumination Code	ILLUMINATION CIRCUIT DIAGRAM
A5	
A6	
A7	
B1	



# Standard Legend Codes

YK	UA	UB	US	UV	UW	UX	UY	MP	MR	PX	MS	MT
VU	MW	NZ	NX	NY	YM	VW	PS	PW	PZ	WG	WM	RN
			NAV LIGHTS	COURT LIGHTS	PANEL LIGHTS	ANCH LIGHTS	HEAD LIGHTS	FOG LIGHTS	DASH LIGHTS	DOCK LIGHTS	BEACON	LIGHT
RP	YG	TX	VD	VE	VF	VG	SH	SM	SN	SP	SR	SY
DIM	BRIGHT						BILGE PUMP	BILGE				
WY	WZ	UH	UJ	PD	PE	PF	VC	VJ	UF	UG	MU	TN
		WIPER										
NS	PB	SE	VZ	YE	NN	RW	PU	WA	YN	UE	NM	RJ
				ENG FAN	BLWR					HORN		
NR	YD	TL	VR	SL	VA	UC	VN	PK	VY	UZ	RH	NU
							UP	DOWN				
NV	RB	RC	RK	RL	MZ	RG	WS	WT	UD	UR	WD	TY
		WATER PUMP			ANCHOR							
PA	UK	WR	UU	UT	YR	PM	VV	WB	TB	TC	TD	TE
											ENG HATCH	ENG BRAKE
MY	PV	TA	TZ	WC	PT	PN	PH	RA	TU	TT	YL	SK
							TCS					
VS	UL	UM	WK	TS	VT	WL	VP	YJ	PJ	RY	UP	NW
NP	RE	RF	PP	PR	TV	PC	YT	YU	PL	WJ	MV	RR
		SEAT					CRUISE					
TK	RT	SZ	VX	WF	WH	PG	SJ	YA	YB	RM	TM	RD
RS	UN	TP	TR	NT	MX	YC	TW	TJ	YF	TH	TF	TG
		AUX	ON OFF	OFF ON	I O	O I	O F F O N	ON	OFF	I	O	II
YS	YH	SX	RZ	YP	WN	WP	WW	WX	SA	SB	SC	SD
RAISE	LOWER	HIGH	LOW	FWD	REV	DEPTH	TRIM TAB	ACC	NAV ANCH	WIND LASS UP/DN	LIVE WELL	REAR
ST	SU	WU	WV	SV	SW	VB	VH	VK	VL	VM	WE	SF
PARK	AUTO											
SG	SS	RU	RV	RX								

## Authorized Sales Representatives and Distributors

Click on a region of the map below to find your local representatives and distributors or visit [www.carlingtech.com/findarep](http://www.carlingtech.com/findarep).



## About Carling

Founded in 1920, Carling Technologies is a leading manufacturer of electrical and electronic switches and assemblies, circuit breakers, electronic controls, power distribution units, and multiplexed power distribution systems. With six ISO9001 and IATF16949 registered manufacturing facilities and technical sales offices worldwide, Carling Technologies Sales, Service and Engineering teams do much more than manufacture electrical components, they engineer powerful solutions! To learn more about Carling please visit [www.carlingtech.com/company-profile](http://www.carlingtech.com/company-profile).

To view all of Carling's environmental, quality, health & safety certifications please visit [www.carlingtech.com/environmental-certifications](http://www.carlingtech.com/environmental-certifications).